OPERATION, MAINTENANCE AND PARTS MANUAL



BACKPACK MODEL 402BP

 **THE WYCO TOOL
COMPANY**
wyco.®

TABLE OF CONTENTS

	Page #
1) Safety	2
2) Benefits of vibration	2
3) Head and shaft selection	2
4) Operation	3
a) Fuel mixture	
b) Speed setting	
c) Combination hour meter and engine tachometer	
d) Starting procedure	
e) Shaft QD attachment	
f) Vibrator insertion	
5) Maintenance	5
a) Flex shaft grease	
b) Vibrator head lubricant	
c) Gear increaser servicing	
d) Robin engine	
6) Service	6
7) Manufacturer's Limited Warranty	6
8) Parts	7
a) Wyco drawings	
b) Robin engine parts	
c) Robin engine warranty	

1. SAFETY

Read and follow all safety precautions given in the Robin engine instruction manual for their EC04ER engine. In addition, read and follow the safety instructions given below:

DANGER

When back pack is worn, the flex shaft must always be on the right hand side of the operator as assembled by the factory. If used on the left side, the muffler exhaust would be directed toward the operator's back, creating a dangerous situation.

Never fill the engine with gas on operator's back or while it is running! If fuel is spilt, wipe it away carefully, and wait until the fuel has dried before starting engine!

Flammable, no smoking!

Never run engine without flex shaft attached. With the flex shaft removed, the rotating shaft is exposed, which

could get entangled with loose clothing, hands and other items causing a dangerous situation.

WARNING

Always wear hearing and eye protection!

Keep hands away from hot metal parts of the engine and speed increaser!

CAUTION

Do not operate the unit above speeds listed in section 4. Excessive speeds will damage the engine and vibrator head and it will void any warranty.

On all gas engine applications, a thread locking compound similar to Loctite #242 should be applied between the head and flex shaft casing end. Torque securely. This will prevent loosening of the head during operation.

2. BENEFITS OF VIBRATION

The following is a list of benefits resulting from vibrating freshly poured concrete.

- 1) Increases concrete strength by removing air voids.
- 2) Improves appearance by removing air voids.
- 3) Increases bond between concrete and reinforcing bars.
- 4) Fluidizes concrete allowing a stiffer mix with a lower water to cement ratio to be placed. This increases concrete strength.
- 5) Reduces cold joints and honey combing

3. HEAD AND SHAFT SELECTION

This unit uses a bearing less quick disconnect. This quick disconnect is required to adapt to the shafts listed. The quick disconnect part # is 402128.

The shafts and heads are the same components used with Wyco's electric vibrators.

Shaft	Head
CK-8900	750-D ($1\frac{3}{16}$ " Square)
	750-EH (1" Square)
CK-9500	750-FI ($1\frac{3}{8}$ " Square)
	750-GI ($1\frac{3}{4}$ " Square)
	750-LI (2" Square)
	750-SBI (2" Round Short)

LI is the largest sized head - recommended with this unit.

Recommended shaft lengths are 7, 10, 14 and 20 feet. Heavy duty flex shafts are available for back pack use in the two most common lengths (7 ft. and 10 ft.). Model numbers for these are BCK9507 and BCK9510. These shafts

4. OPERATION

Read and follow the instructions given in the Robin engine instruction manual for their EC04ER engine with the following exceptions:

- 1) This engine does not come with a fuel cock.
- 2) Fuel strainer is located on end of tube inside gas tank.
- 3) An additional speed adjustment feature is included which limits the maximum speed.
- 4) A dual function hour meter and tachometer is also included, which will display engine speed and record hours of usage.

a) Fuel mixture

Use only high quality ash less 2-cycle engine oils. Do not use automotive motor oil. The Robin brand of 2-cycle oil is highly recommended when available. Use fresh unleaded gas pumped less than 3 months prior to use. Mix gas and 2-cycle oil at a 24:1 ratio during the first 10 tanks or approximately 10 hours. This is called the "break in" period. After the "break in" period a 32:1 ratio may be used as long as a quality 2-cycle engine oil is used as described above.

have reinforcing springs and special cores which increase life in this application.

Use the head size that best matches the application. Consider the vibrator's radius of action when selecting a vibrator head, ensuring that the entire area of concrete is vibrated. A vibrator's radius of action is approximately 4 times the head size. This is a general guide, and it can vary significantly with variations in concrete mix design and type of application. The radius of action is the circular field around the vibrator that acts like a liquid.

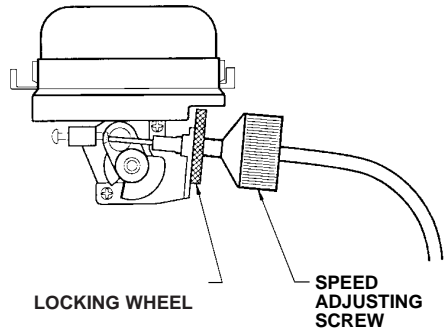

b) Speed setting

A speed adjusting screw and a locking wheel is located where the throttle cable attaches to the engine. To set the maximum speed, do the following:

- 1) Assemble the back pack to the flex shaft and vibrator head to be used.
- 2) Start engine and warm up unit. If the unit is not warmed up to operating temperature, and the flex shaft is not broke in, it will run faster than necessary and must be readjusted.
- 3) Open throttle lever to the maximum speed.
- 4) Loosen locking wheel
- 5) Turn the speed adjuster to the desired speed.
- 6) Tighten the locking wheel toward the carburetor to secure.

Do not operate this unit at speeds greater than listed as follows. Speeds greater than listed will cause premature failure of the engine and head due to excessive speeds. This will void any warranty.

The engine tachometer will show the engine speed, and the head speed is twice the engine speed.

<u>Head size</u>	<u>Engine RPM</u>	<u>Head VPM</u>
D	6,500	13,000
EH	6,250	12,500
FI	6,000	12,000
GI	5,875	11,750
LI	5,750	11,500
MI	5,500	11,000
SBI	6,000	12,000

c) Combination hour meter and engine tachometer

To toggle between Usage hours and Engine speed, press the button. The speed shown is the RPM of the engine. The vibrator speed (VPM) is twice the engine speed.

The meter will switch to hours and lock every 25 hours. A service icon will also appear. The backpack, flex shaft and vibrator heads require maintenance every 50 hours. To reset, press and hold the button on the meter for 7 seconds.

d) Starting procedure

- Always check for gas tank and fuel hose gas leaks before using engine.
- Insure proper mixture of fresh fuel is in tank.
- Insure switch is on.
- Adjust throttle to approximately 1/2 speed.
- Push primer 5 to 7 times
- If engine is cold, place choke to the closed position.
- Pull starter rope quickly, but do not pull to the point were additional rope does not come out.
- If the engine pops without starting, set choke to 1/2 open and pull again.

e) Shaft QD attachment

Insure that the quick disconnect (Wyco #402128) is attached to the CK-9500 series, BCK-9500 series, or CK-8900 series flexible shaft. To attach the flexible shaft to the backpack, pull the ring and insert the quick disconnect into the aluminum housing, insuring that the hex end of the core is engaged. Rotate the adapter until the pin engages in the slot. To remove flexible shaft, pull ring and pull the quick disconnect adapter out.

On all gas engine applications, a thread locking compound similar to Locktite #242 should be applied between the head and flex shaft casing end. Torque securely. This will prevent loosening of the head during operation.

f) Vibrator insertion

Insert vibrator vertically, allowing it to penetrate rapidly to the bottom of the lift at least 6 inches into any previous lift. Hold the vibrator at the bottom of the lift for 5 to 15 seconds. Pull vibrator up at a rate of 15 seconds for a 4-foot lift. Insure that the radius of actions overlap (distance between vibrators 1.5 times the radius of action).

5. MAINTENANCE

a) Flex shaft grease

After each 50 hours of use, re-grease the flex shaft with Wyco synthetic shaft grease # 514B.

b) Vibrator head lubricant

If the vibrator head used is oil lubricated, after 50 hours of use, change oil with Wyco lubricant #514-O.

c) Gear increaser servicing

After 250 hours of operation, the gear increaser assembly should be disassembled, thoroughly cleaned and reassembled with 1 ounce Wyco gear oil SF 1000 (Wyco #402151, 8 oz.) While disassembled, check to see if the centrifugal clutch or the clutch drum need replacing due to wear. A replacement clutch kit is available, see drawing #402006 attached. Use Wyco drawing #402000, and 402002 at the back of this manual as a reference while assembling and disassembling.

- 1) Remove the socket head cap screws holding the speed increaser housing to the engine.
- 2) Remove the socket head cap screw, standoff, washer and lockwasher attaching the base of the motor to the mounting bracket.
- 3) Remove the socket head cap screws and lockwashers mounting the throttle lever onto the speed increaser housing.
- 4) Clamp the speed increaser housing in a vise.
- 5) Hold the clutch drum in place using a chain wrench or oil filter style wrench and unscrew the hex driver on the opposite end with a 5/16" allen wrench. (The clutch drum thread should loosen first. If it doesn't, the internal gear must be locked in place while unscrewing the clutch

drum. It can be clamped in place by screwing in a 1/4-28 a screw into the plugged hole on the bottom of the speed increaser housing.) The screw will push against the internal gear holding it in place while unscrewing the clutch drum.

- 6) With the clutch drum removed, remove the large snap ring. This will allow the slow speed shaft assembly to be pulled out. The clutch drum should be screwed back on to ease removal. If this assembly is difficult to remove. Tap on the internal gear through the plugged hole on the bottom of the speed increaser housing.
- 7) Remove the snap ring holding the high-speed shaft assembly in place. Then remove the shaft assembly.
- 8) Clean and inspect the shaft assemblies. Check that the bearings turn smooth and freely. If not, replace them.
- 9) Reassemble in reverse order. Before inserting the slow speed shaft assembly, fill the internal gear with 1 ounce of Wyco gear oil SF 1000 (1 ounce will completely fill the internal gear). Use a thread-locking compound (Loctite 242 or similar) on the high speed shaft hex driver threads if the driver was removed. Tighten the hex driver and clutch drum after the speed increaser is assembled.

d) Robin engine

Follow the recommendations in the Robin engine instruction manual for their EC04ER engine regarding, but not limited to, the spark plug and air filter service. When changing the spark plug use NGK #BMP7A (Champion CJ6Y or CJ7Y) with a .02 to .03 inch gap.

6. SERVICE

Repair or replacement parts can be ordered from The Wyco Tool Company. Warranty repairs or chargeable repairs can be made by sending the product to the following address. Always obtain a RA number (Return Authorization) and include it in the address before returning any parts for warranty consideration or chargeable repair.

Phone # (262) 639-6770

or

Toll free # (800) 233-9926

RA#

The Wyco Tool Company
8635 Washington Avenue
Racine, Wisconsin 53406-3738

Engine parts may be obtained from The Wyco Tool Company or found locally at an authorized Robin dealer. To locate a Robin dealer in your area, call (630) 350-8200 or use their web page at www.robinamerica.com.

7. MANUFACTURER'S LIMITED WARRANTY

The WYCO Tool Company warrants that the products manufactured by it, when properly assembled, used and maintained, shall be free from defects in material or workmanship, and will perform according to the manufacturer's specifications under normal conditions, subject to the limitations stated in this Manufacturer's Limited Warranty.

WYCO's obligation under this warranty shall be limited to repairing or replacing the part or parts, or, at WYCO's option, the products that prove defective upon return to the manufacturer's factory. Cost of transportation and other expenses connected with replacing parts are not covered.

WYCO's obligation under this Warranty is limited to a period of 12 months from the date of purchase.

Written authorization from WYCO is required before any product can be returned for warranty consideration. Always obtain a RA number (Return Authorization) and include it in the address before returning any parts for warranty consideration or chargeable repair.

WYCO is not liable for any consequential damages or any contingent liabilities arising out of the failure of product manufactured by it, or any component part or accessory.

This Manufacturer's Limited Warranty is in lieu of all other warranties. All other warranties, either express or implied, arising by operation of law, course of dealing, usage of trade or otherwise are excluded.

THERE ARE NO IMPLIED WARRANTIES OF MERCHANTABILITY OR FITNESS FOR A PARTICULAR PURPOSE.

No agent, representative or distributor has any authority to alter the terms of this warranty in any way.

Robin America, Inc warrants their engine under a separate warranty. A copy of the Robin America, Inc warranty is attached.

8. PARTS

a) Wyco drawings

<u>Description</u>	<u>Drawing #</u>
Back pack assembly	402000
Frame assembly	402001
Speed increaser assembly	402002
Quick disconnect	402128
Replacement Clutch Kit	402006

b) Robin engine parts (When Wyco #s are listed, they are available directly from Wyco.)

c) Robin engine warranty

402000 – ASSY. BACKPACK UNIT

NOTE: THIS VIEW DOES NOT SHOW SHOULDER STRAP

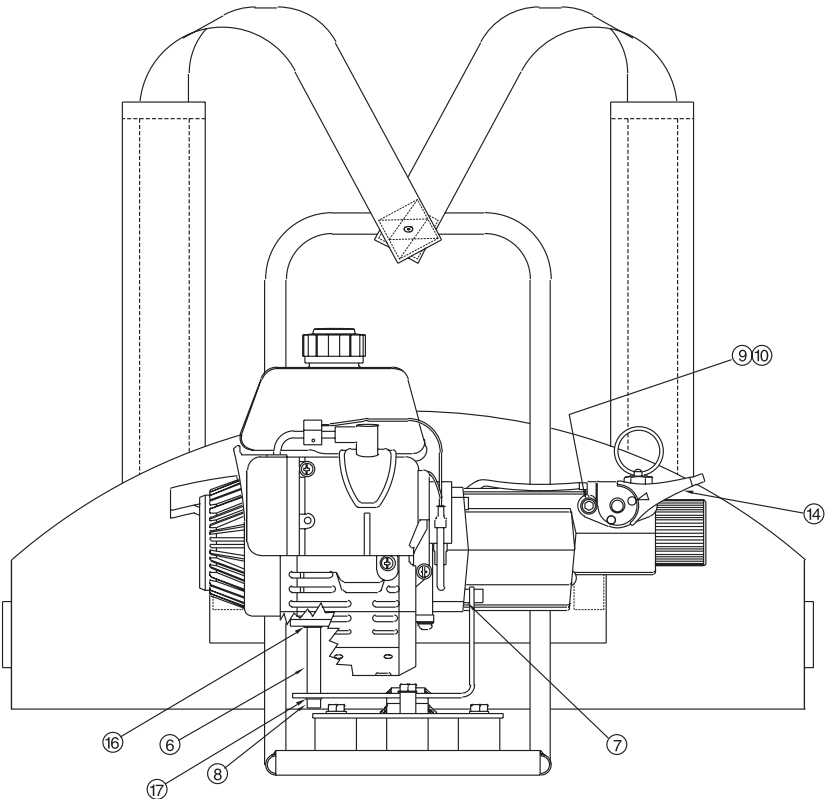
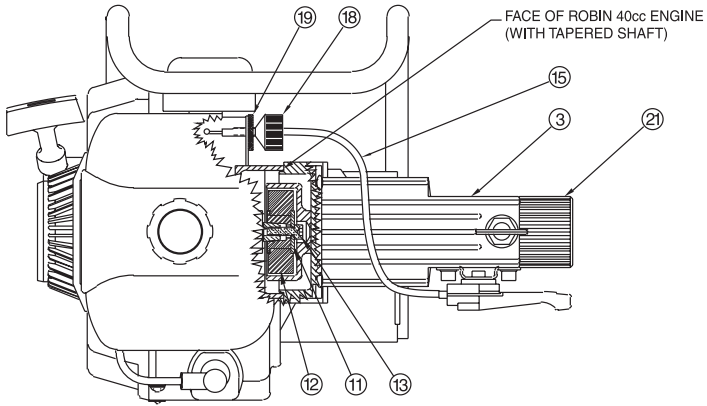

ITEM	PART #	QTY.	DESCRIPTION	ITEM	PART #	QTY.	DESCRIPTION
1	402001	1	ASSY. FRAME, BACK- PACK UNIT; ROBIN	11	402168	1	WASHER, FLAT; CLUTCH
2	402100	1	ENGINE, ROBIN; 40.2cc; AIR COOLED	12	402167	1	CLUTCH, CENTRIFICAL
3	402002	1	ASSY, SPEED INCREASER; BACKPACK	13	402169	1	SCREW, SOCKET HEAD CAP; SELF LOCK, M6 X 20mm
4	402113	2	SCREW, SOCKET HEAD CAP; M6 x 45mm	14	402148	1	LEVER, THROTTLE; BACKPACK; ROBIN
5	402114	2	SCREW, SOCKET HEAD CAP; M6 x 30mm	15	402149	1	CABLE, THROTTLE; BACKPACK; ROBIN
6	402122	1	STANDOFF, LONG; BACKPACK; BLACK OXIDE	16	402139	1	WASHER, FLAT, ENGINE MOUNT; M6
7	402123	2	STANDOFF, SHORT; BACKPACK; BLACK OXIDE	17	402140	1	WASHER, LOCK; ENGINE MOUNT; M6
8	402120	1	SCREW, SOCKET HEAD CAP; M6 x 70mm	18	402143	1	ADJUSTER, SPEED LIMITER; BACKPACK
9	402116	2	SCREW, SOCKET HEAD CAP; 1/4-20 x 3/8	19	402144	1	WHEEL, LOCKING; ADJUSTER; BACKPACK
10	402117	2	WASHER, LOCK; STEEL, 1/4"	20	402154	1	METER, RPM/HOUR
				21	402128	1	ADAPTOR, QUICK DISCONNECT, BLACK OXIDE

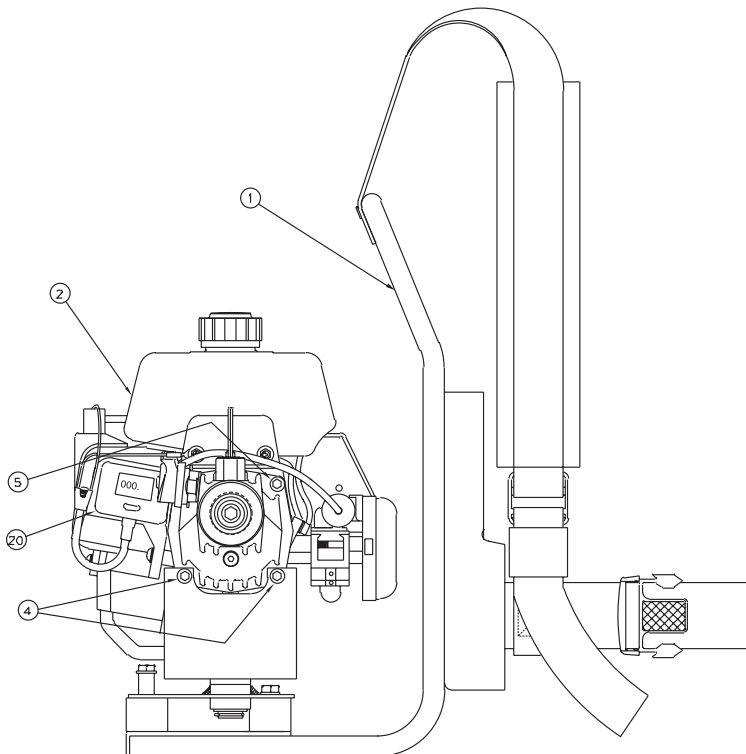

402001 – ASSY. FRAME BACKPACK UNIT

ITEM	PART #	QTY.	DESCRIPTION	ITEM	PART #	QTY.	DESCRIPTION
1	402115	1	FRAME, BACKPACK; BEND/WELD	7	883126	6	WASHER, LOCK; 5/16"
2	402111	3	ISOLATOR, RUBBER; BACKPACK	8	402103	1	PLATE, MOUNTING; ISOLATOR; BACKPACK
3	402138	1	ASSY, BRACKET; ENGINE MOUNT; BACKPACK	9	402112	1	BEARING, OIL-IMPREG; FLANGE; BACKPACK
4	402147	1	BUMPER, STANDOFF; BACKPACK; BLACK OXIDE	10	402109	1	RING, RETAINING; EXTERNAL
5	402145	1	SCREW, HEX HEAD CAP; 5/16 x 1.25	11	402129	1	SHOULDER STRAP, BACKPACK UNIT
6	402108	5	SCREW, HEX HEAD CAP; 5/16 x .50	12	415311	3	RIVET, POP; STEEL PLATED

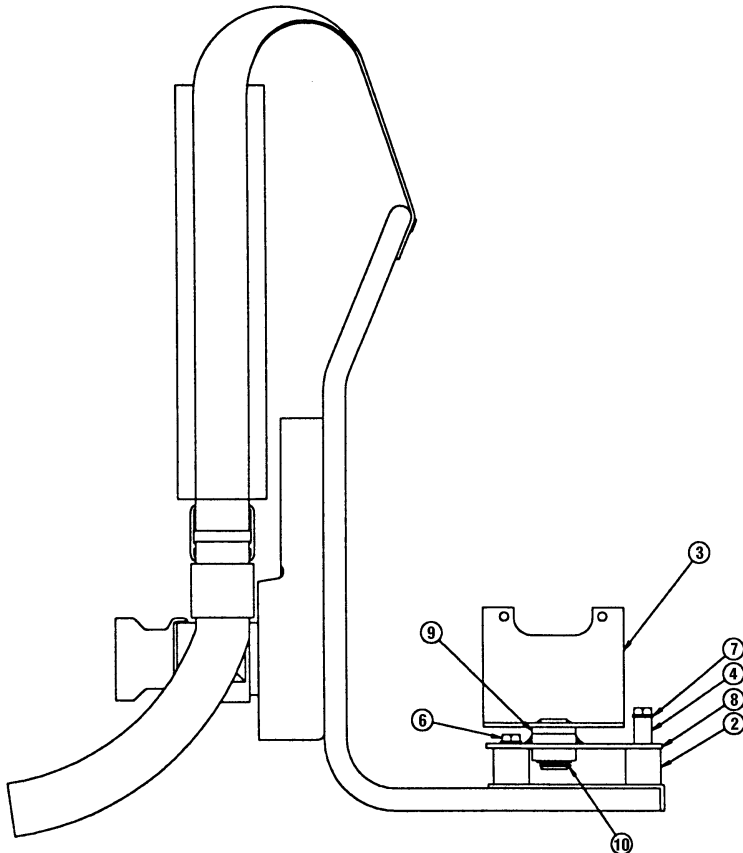

NOTE: THIS VIEW DOES NOT SHOW SHOULDER STRAP

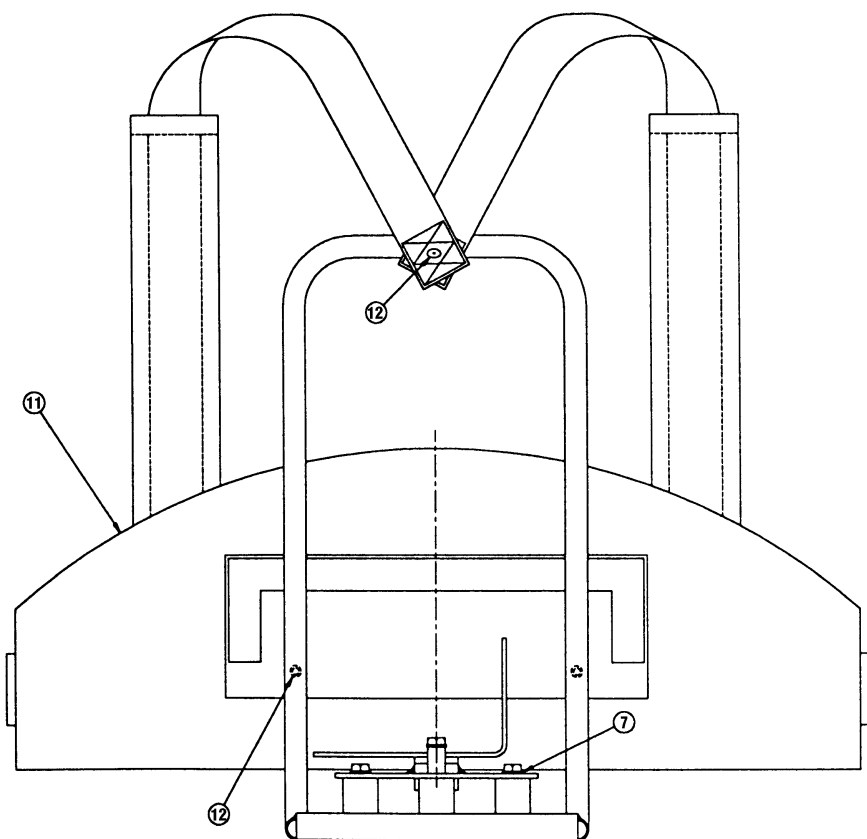
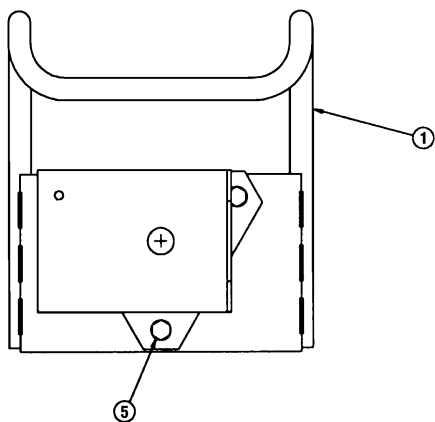

402002 – ASSY, SPEED INCREASER

ITEM	PART #	QTY.	DESCRIPTION	ITEM	PART #	QTY.	DESCRIPTION
1	803701	1	SPRING, C0390-047-1000-S	11	402102	1	HOUSING, SPEED INCREASER; MACHINED
2	343703	1	PLUNGER, BLACK OXIDE	12	612210	1	KEY, WOODRUFF
3	703701	1	RING, SPLIT	13	402104	1	SHAFT, INPUT; SPEED INCREASER
4	113706	1	PLUNGER BODY; BLACK OXIDE	14	402133	1	GEAR, INTERNAL
5	402125	1	RING, RETAINING; INTERNAL	15	402152	1	SCREW, BUTTON CAP; 1/4-28 X .25
6	402126	1	SHAFT, PINION GEAR	16	419661	4	BEARING, BALL; DEEP GROOVE
7	402105	1	BEARING ADAPTER; SPEED INCREASER	17	402136	1	DRIVER, HEX; BACK-PACK; BLACK OXIDE
8	402107	1	RING, SNAP; STEEL	18	402153	1	WASHER, NYLON; .252 ID X .472 OD
9	402166	1	CLUTCH DRUM				
10	402131	2	SPACER, BEARING				

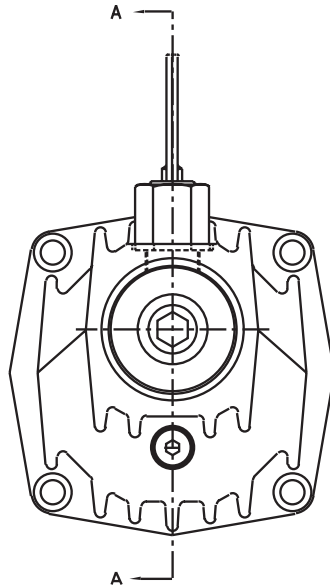

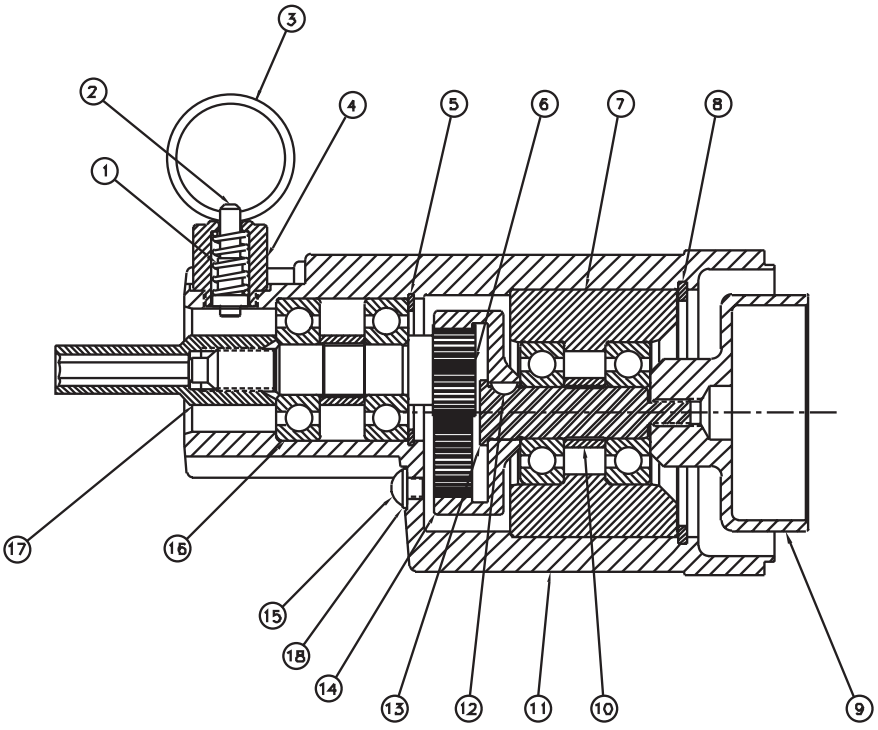

SECTION A-A
(PARTIAL VIEW)

SECTION A-A (PARTIAL VIEW)

402128 – QUICK DISCONNECT, BP

**FLEX SHAFT
CASING END**

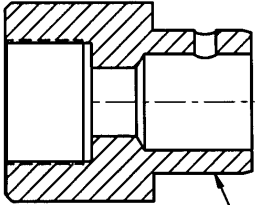

SECTION A-A

1

**BACK PACK
SPEED
INCREASER**

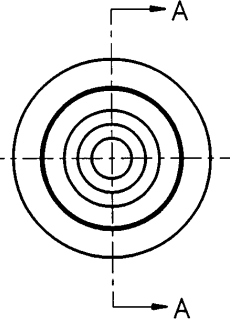

402006 – REPLACEMENT CLUTCH KIT

REF.	PART #	PART NAME	QTY.	REMARKS	INTERCHANGEABLE PART NUMBER
	402166	DRUM, CLUTCH; NORAM	1		
	402167	ASSY, CLUTCH; NORAM	1		
	402168	WASHER, FLAT; CLUTCH	1		
	402169	SCREW, SOCKET HEAD CAP; SELF LOCK; M6 X 20mm	1		

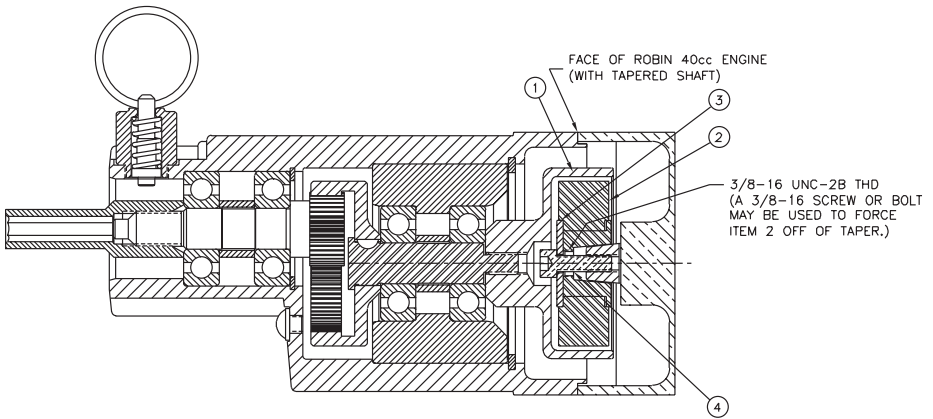

**ROBIN
PARTS
CATALOG**

(When Wyco part numbers
are listed, they are
available directly
from Wyco.)

FIG. 100 – CRANKCASE & CYLINDER

REF.	PART #	PART NAME	QTY.	REMARKS	INTERCHANGEABLE PART NUMBER
10	541-10050-00	CRANKCASE CP	1		
15	541-15012-00	GASKET (CRANKCASE)	1		
30	044-01599-71	OIL SEAL	2	TC15257	KN21-116A
40	060-01598-80	BALL BEARING	2	BB6202C3	
95	011-90599-40	SOCKET HEAD BOLT	4		EC03-9302
170	541-15005-00	CYLINDER PACKING	1		
510	541-15003-00	CYLINDER	1		
630	011-90699-90	SOCKET HEAD BOLT	4		EC03-152

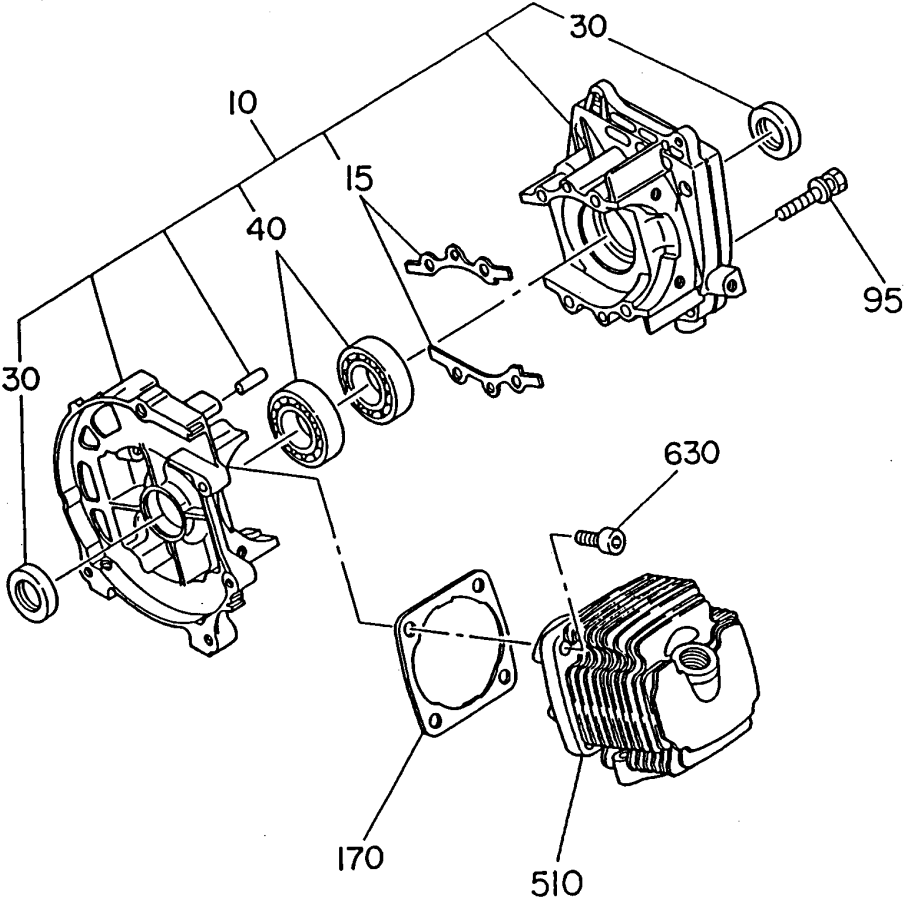

FIG. 200 – CRANKCASE & PISTON

REF.	PART #	PART NAME	QTY.	REMARKS	INTERCHANGEABLE PART NUMBER
10	541-20010-00	CRANKSHAFT AY	1		
55	001-67061-60	BOLT	1		
60	003-20060-00	SPRING WASHER	1		
65	020-00699-20	WASHER	1		
70	032-30399-90	WOODRUFF KEY	1		
90	620-25006-00	WASHER	1		NB02A-207
100	001-66061-60	BOLT	1		
101	003-20060-00	SPRING WASHER	1		
350	541-25003-00	PISTON PIN	1		
360	541-25008-00	PISTON	1		
370	540-25006-00	PISTON RING	2		EC04-210A
380	056-50999-90	CLIP	2		
390	541-25013-00	NEEDLE BEARING	1		

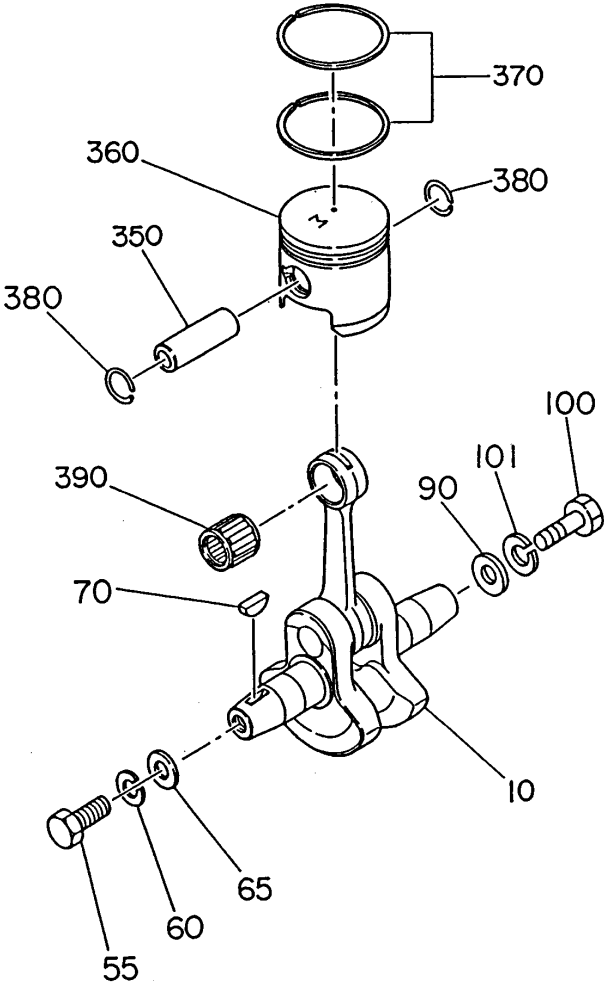

FIG. 300 – MUFFLER

REF.	PART #	PART NAME	QTY.	REMARKS	INTERCHANGEABLE PART NUMBER
310	532-30060-00	MUFFLER CP	1	Wyco #402201	
320	541-35001-00	MUFFLER COVER	1	Wyco #402226	
340	532-35002-00	GASKET (MUFFLER)	1	Wyco #402225	
360	004-37061-60	SCREW AY	2		
361	004-37051-40	SCREW AND WASHER AY	1		
370	011-90698-30	SOCKET HEAD BOLT	2		
380	003-10060-00	WASHER	2		

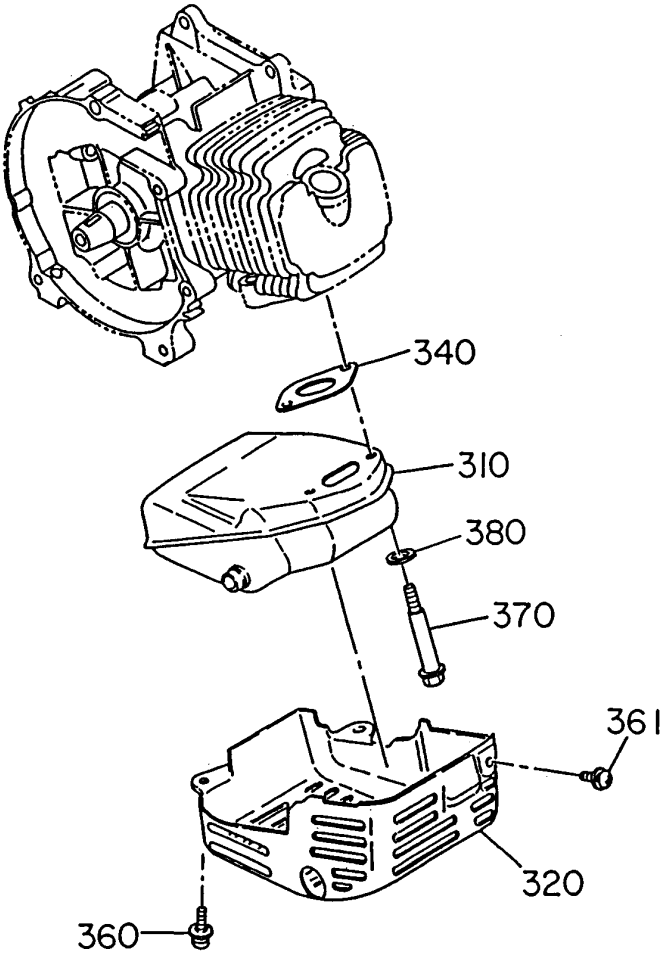

FIG. 310 – AIR CLEANER

REF.	PART #	PART NAME	QTY.	REMARKS	INTERCHANGEABLE PART NUMBER
510	541-30440-10	HOUSING	1	Wyco #402227	
511	523-30130-20	CLEANER COVER	1	Wyco #402202	
512	531-30030-50	WASHER	1		
513	523-30130-30	SLEEVE	2		
514	523-30130-40	PLATE	1		
515	531-30031-10	CLIP	1		
516	531-30030-30	CHOKE VALVE	1		
520	541-30440-20	FILTER	1	Wyco #402203	
580	011-90598-10	SOCKET HEAD BOLT	2		

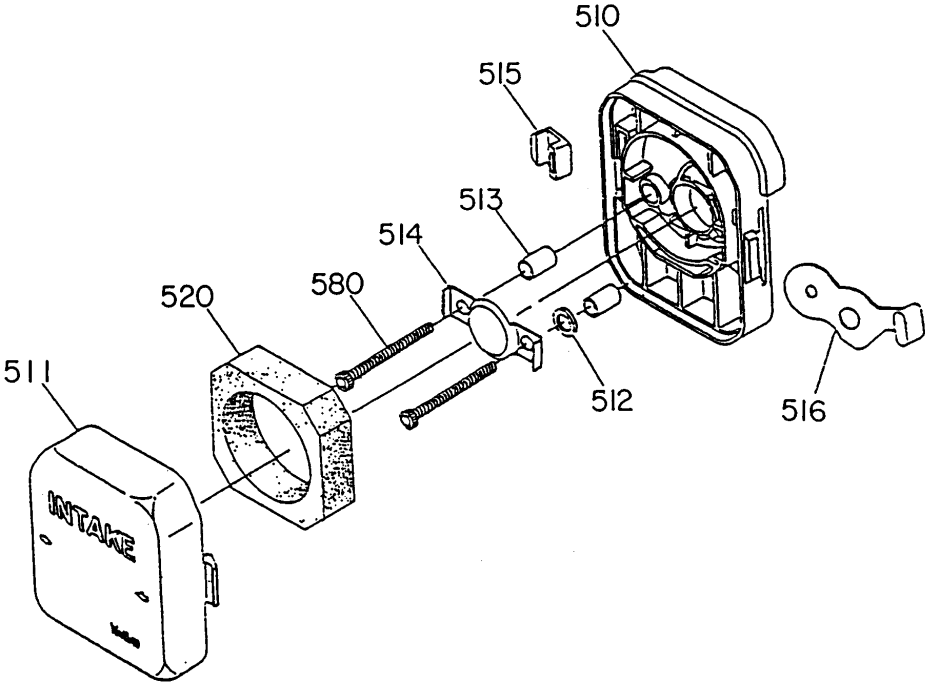
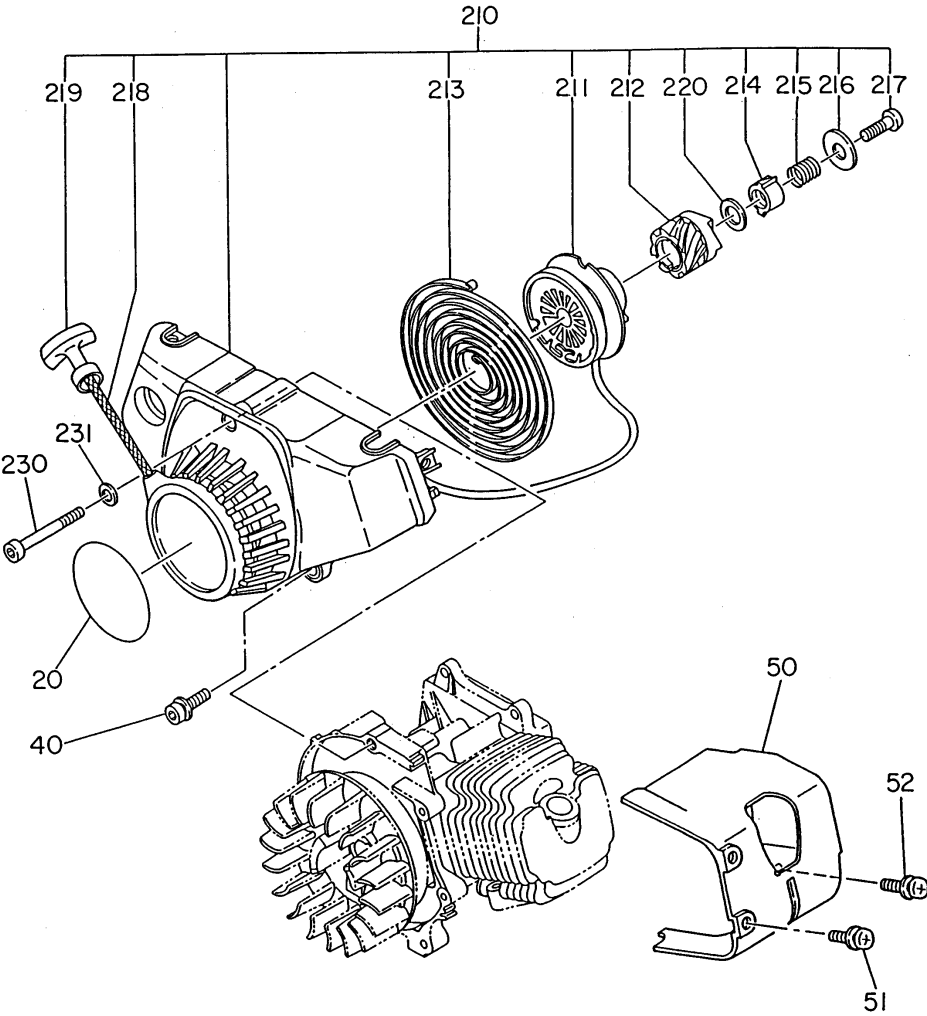
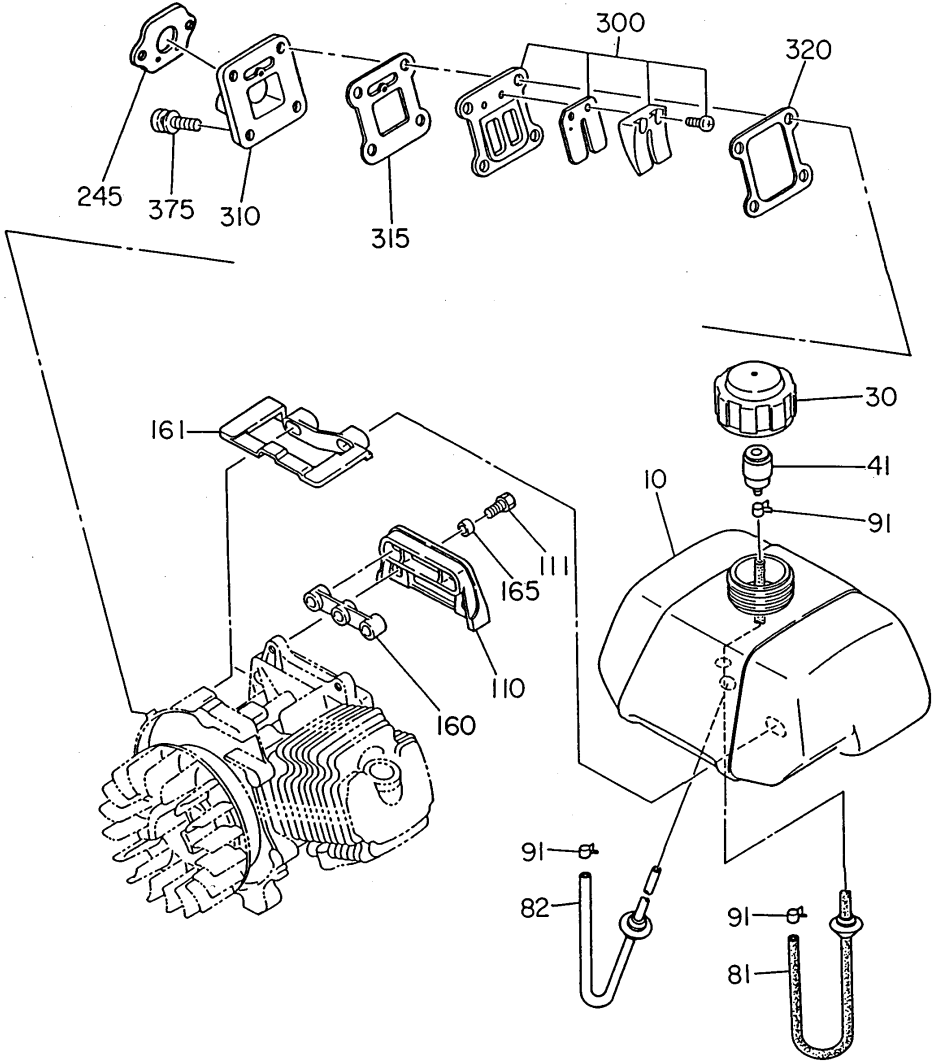

FIG. 500 – RECOIL STARTER AY



REF.	PART #	PART NAME	QTY.	REMARKS	INTERCHANGEABLE PART NUMBER
20	541-95002-00	LABEL (MODEL)	1		
40	011-90597-90	SOCKET HEAD BOLT	2		
50	541-55003-00	CYLINDER COVER	1		
51	004-37051-40	SCREW AND WASHER AY	1		
52	004-37052-00	SCREW AND WASHER AY	1		
210	541-50400-00	RECOIL STARTER AY	1	Wyco #402204	
211	541-50010-10	REEL	1	Wyco #402205	
212	541-50010-20	RATCHET	1	Wyco #402206	
213	541-50010-30	SPIRAL SPRING	1	Wyco #402207	
214	541-50010-40	RATCHET GUIDE	1	Wyco #402208	
215	541-50010-50	FRICTION SPRING	1	Wyco #402209	
216	541-50010-60	WASHER	1		
217	524-50010-10	BIND SCREW	1		
218	541-50011-40	STARTER ROPE	1	Wyco #402210	
219	530-50021-10	STARTER KNOBE CP	1	Wyco #402211	
220	541-50012-20	THRUST WASHER	1		
230	011-90596-60	SOCKET HEAD BOLT	1		
231	003-10050-00	WASHER	1		

FIG. 600 - FUEL TANK



REF.	PART #	PART NAME	QTY.	REMARKS	INTERCHANGEABLE PART NUMBER
10	541-65041-00	FUEL TANK	1	Wyco #402212	
30	531-60150-00	FUEL TANK CAP	1	Wyco #402213	
41	523-65039-00	FILTER	1	Wyco #402214	
81	085-12799-70	TUBE AY BLACK	1	Wyco #402215	
82	085-12899-60	TUBE AY CLEAR YELLOW	1	Wyco #402216	
91	056-10599-90	HOSE CLAMP	3	Wyco #402217	EC01A-6070
110	541-65003-00	TANK BRACKET CP	1		
111	001-17051-40	BOLT AY	2		
160	541-65011-00	RUBBER CUSHION (B)	1		
161	541-65019-00	RUBBER CUSHION (A)	1		
165	023-00599-90	SPACER	2		EC01A-6027
245	541-65040-00	GASKET CARBURETOR	1		
300	541-30060-00	LEAD VALVE AY	1		
310	540-30480-01	INSULATOR AY	1		
315	540-35006-00	GASKET INSULATOR	1		
320	541-35028-00	PACKING	1		
375	011-90596-40	SOCKET HEAD BOLT	4		

FIG. 610 – CARBURETOR

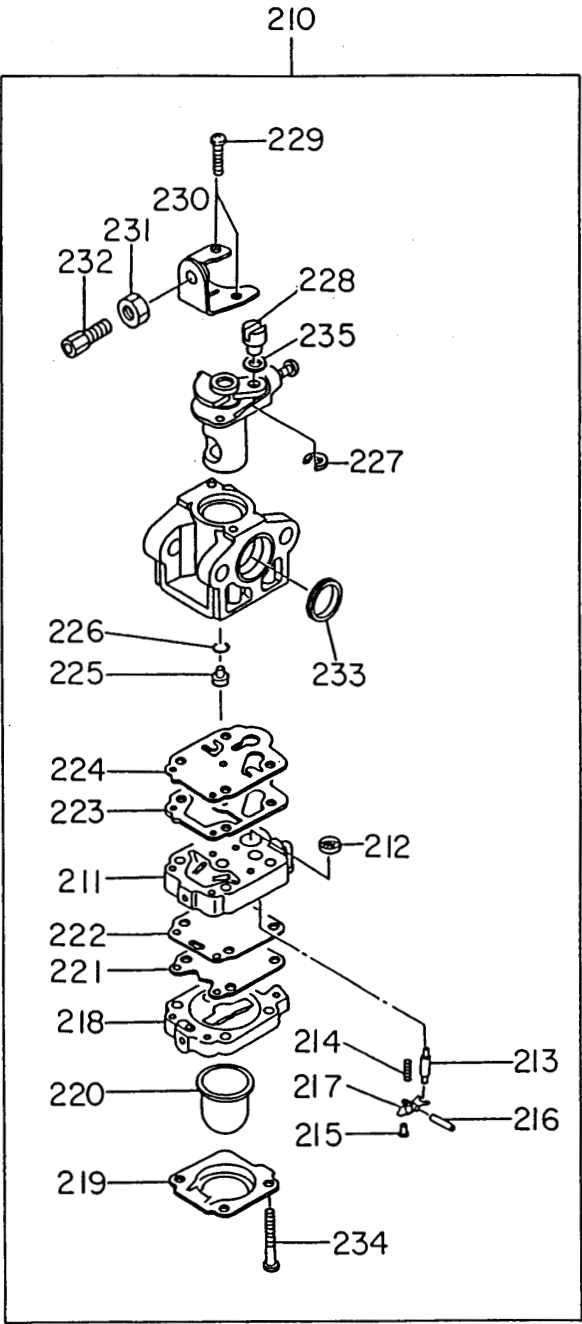

REF.	PART #	PART NAME	QTY.	REMARKS	INTERCHANGEABLE PART NUMBER
210	541-60460-00	CURBURETOR	1	Wyco #402218	
211	523-60461-30	BODY AY-PUMP	1		
212	501-60040-10	SCREEN	1	Wyco #402219	
213	531-60051-50	VALVE-INLET	1	NOT FOR SALE	
214	523-60461-20	SPRING	1	NOT FOR SALE	
215	523-60461-10	SCREW	1	NOT FOR SALE	
216	531-60055-10	PIN	1	NOT FOR SALE	
217	531-60055-50	LEVER	1	NOT FOR SALE	
218	523-60460-60	BODY AY-AIR PURGE	1		
219	523-60460-50	COVER	1		
220	524-60011-50	PUMP	1	Wyco #402220	
221	531-60052-50	DIAPHRAGM AY	1	Wyco #402228	
222	523-60460-40	GASKET	1	Wyco #402229	
223	524-60010-40	DIAPHRAGM	1	Wyco #402230	
224	524-60010-30	GASKET	1	Wyco #402231	
225	541-60460-10	JET	1		
226	524-60010-10	O-RING	1		
227	531-60051-20	RING	1		
228	523-60180-40	SWIVEL	1		
229	524-60012-40	SCREW	2		
230	523-60520-20	BRACKET	1		
231	531-60054-50	NUT	1		
232	521-60080-10	ADJUSTER SCREW	1		
233	523-60180-20	RING	1		
234	523-60460-10	SCREW	4		
235	523-60520-30	WASHER	1		

REF.	PART #	PART NAME	QTY.	REMARKS	INTERCHANGEABLE PART NUMBER
10	541-70230-10	FLYWHEEL	1		
11	541-70230-20	IGNITION COIL	1	Wyco #402224	
18	541-75003-00	TUBE	1		
30	011-90597-90	SOCKET HEAD BOLT	2		
60	066-20097-20	STOP SWITCH	1	Wyco #402223	
61	541-75006-00	PLATE	1		
70	015-00499-80	TAPPING SCREW	2		
90	541-75001-00	EARTH SPRING	1		
95	065-40099-31	SPRING, PLUG CAP	1		
100	065-01497-10	SPARK PLUG	1	NGK BPM7A	Wyco #402221
110	541-75000-00	SPARK PLUG CAP	1		
250	073-62599-61	LABEL	1		

FIG. 900 – ACCESSORIES

REF.	PART #	PART NAME	QTY.	REMARKS	INTERCHANGEABLE PART NUMBER
10	530-90030-00	ACCESSORY TOOL KIT	1		

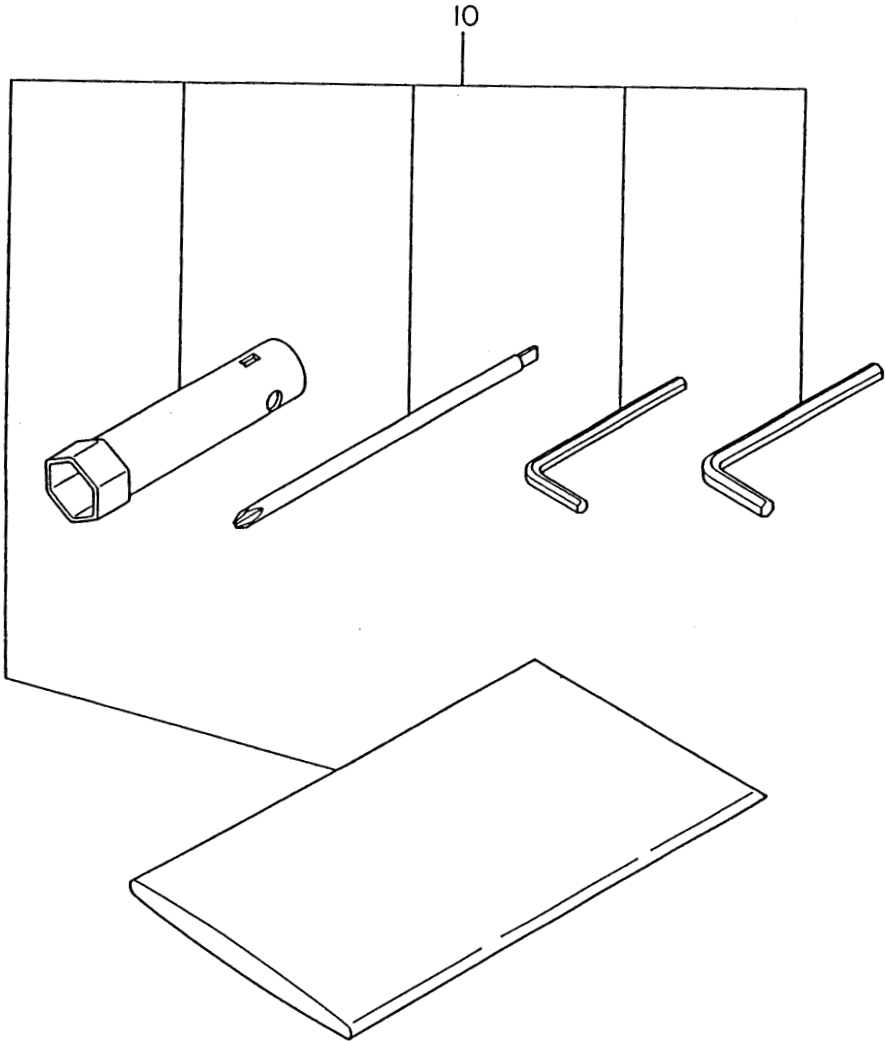
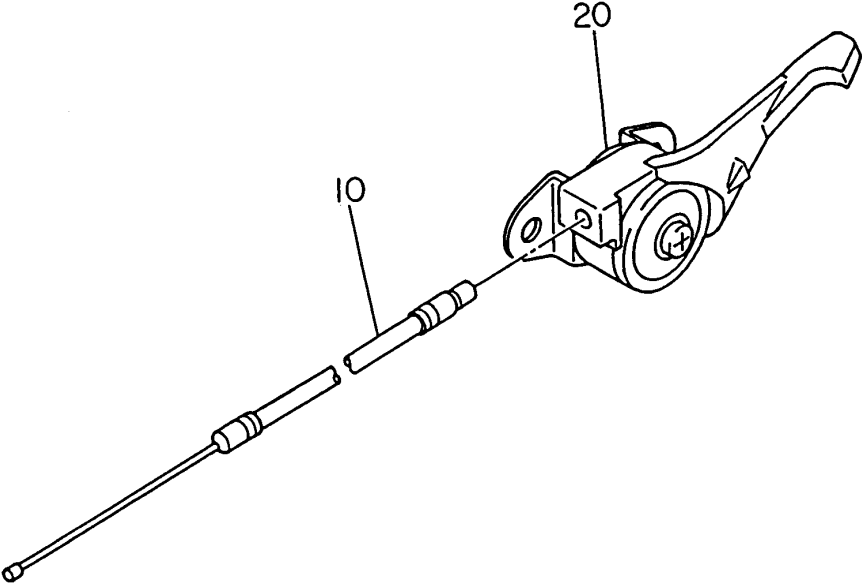

FIG. 1000 – OTHERS

REF.	PART #	PART NAME	QTY.	REMARKS	INTERCHANGEABLE PART NUMBER
10	063-00299-80	CONTROL CABLE	1	Wyco #402149	
20	063-10098-11	CONTROL LEVER	1	Wyco #402148	



LIMITED ENGINE WARRANTY

For Robin Two-Cycle, Air-cooled, Gasoline Engines and Robin Four-Cycle, Air-cooled, Diesel Engines

(Effective with engines purchased from Robin America, Wood Dale, IL, after November 15, 1993.)

Robin America, Inc., a division of Fuji Heavy Industries, Ltd. (herein "Robin"), warrants that each new engine sold by it will be free, under normal use and service, from defects in material and workmanship for a period of one (1) years from the date of sale to the original retail purchaser. Robin's obligation under this Limited Warranty shall be limited to the repair and replacement, at Robin's option, of any part or parts which upon examination is/are found, in Robin's judgement, to have been defective in material or workmanship. It shall be a condition of Robin's obligation under this Limited Warranty that Robin, directly or through one of its Distributors or Service Centers authorized to service the particular engine involved, receive prompt notice of any warranty claim and that the engine or the part or parts claimed to be defective be promptly delivered, transportation prepaid, to such Distributor or Service Center for inspection and repair. All repairs qualifying under this Limited Warranty must be performed by Robin or one of its authorized Distributors or Service Centers.

The repair or replacement of any part or parts under this Limited Warranty shall not extend the term of the engine warranty beyond the original term as set forth above.

LIMITATIONS AND EXCLUSIONS: The Limited Warranty shall not apply to:

1. Bent or broken crankshaft or resultant damage caused by vibration related to a bent or broken crankshaft. Also, damage caused by loose engine mounting bolts or improper or imbalanced accessories or blades mounted to the crankshaft.
2. Repairs required because of prolonged storage including damage caused by old or contaminated fuel in the fuel tank, fuel lines or carburetor, sticky valves or corrosion and rust of engine parts.
3. Repair required due to overheating. (Most often caused by overloaded or clogged or damaged or missing flywheel fan inlet air passages, cooling fins or air shrouds.)
4. Dirt or grit related wear caused by improper air cleaner maintenance (most often resulting in worn piston, piston rings, cylinders, valves, valve guides, carburetor or other internal components).
5. Broken or scored parts caused by low oil level dirty or improper grade of oil.
6. engine tune-ups and normal maintenance service including, but not limited to, valve adjustment, normal replacement of service items, fuel and lubricating oil, etc.
7. Any engine which has been subject to negligence, misuse, accident, mis-application or overspeeding.
8. Any engine that has been installed, repaired, or altered by anyone in a manner which in Robin's sole judgement adversely affects its performance or reliability.
9. Any engine which has been fitted with or repaired with parts or components not manufactured or approved by Robin in which Robin's sole judgement adversely affects its performance or reliability.
10. Instances when normal use has exhausted the life of a component or an engine.

The customer is responsible for all transportation charges in connection with any warranty work.

Robin reserves the right to modify, alter or improve any engines or parts without incurring any obligation to modify or replace, any engine parts previously sold without such modification, alteration or improvement.

No person is authorized to give any other warranty or to assume any additional obligation on Robin's behalf unless made in writing and signed by an officer of Robin.

THIS WARRANTY, AND ROBIN'S OBLIGATION HERE UNDER, ARE IN LIEU OF ANY OTHER WARRANTIES OR OBLIGATIONS OF ANY KIND, EXPRESSED OR IMPLIED, INCLUDING ANY WARRANTIES OF MERCHANTABILITY OR FITNESS FOR A PARTICULAR PURPOSE. THERE ARE NO WARRANTIES WHICH EXTEND BEYOND THE DESCRIPTION OF THE FACE HEREOF. ROBIN SHALL IN NO EVENT BE LIABLE FOR ANY CONSEQUENTIAL OR INCIDENTAL DAMAGES.



**THE WYCO TOOL
COMPANY**

8635 Washington Avenue • Racine, WI 53406-3738
Telephone: 262-639-6770 or 1-800-ADD-WYCO
(233-9926)
Facsimile: 262-639-2023 or 1-888-WYCO-USA
(992-6872)