



BD Pneumatic Concrete Vibrator

- Variable air flow rate, twist grip throttle
- Easy to handle
- Quiet, smooth operation

Sizes: BD-35, 1-1/2"
BD-55, 2-1/4"
BD-65, 2-3/4"
BD-75, 3"



Principles of Operation

The BD Pneumatic Concrete Vibrator series feature a built-in pneumatically driven motor which has only two moving parts, the vane (1) and rotor (2). Compressed air is supplied to the vibrator through the air valve and inner hose (3). Air flows into the rotor, passes through the passage ways in the vane, back through the "air gap" on the rotor and outer holes in the rear flange. This activates the rotor and the vibrator begins to vibrate.

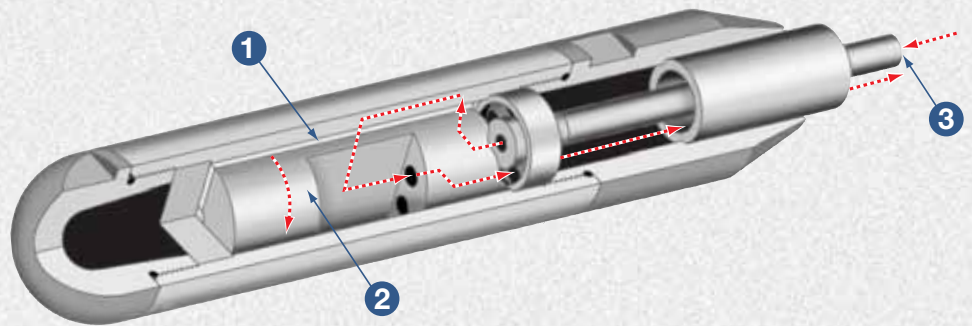

Specifications

MODEL	Head Diameter inches (mm)	Head Length inches (mm)	Head Weight lbs (kg)	Amplitude (total at tip) inches (mm)	Frequency (max. at 85 psi) vpm	Centrifugal Force (max. at 85 psi) lbs (kg)	Air Consumption (max. at 85 psi) cfm
BD35	1.42 (36)	10.51 (267)	3.3 (1.5)	.027 (.69)	17,600	441 (200)	27
BD55	2.20 (56)	13.54 (344)	9.9 (4.5)	.037 (.94)	17,700	1484 (675)	54
BD65	2.64 (67)	14.37 (365)	17.38 (7.9)	.054 (1.37)	17,700	2548 (1158)	54
BD75	3.03 (77)	15.67 (398)	19.6 (8.9)	.070 (1.78)	17,000	3278 (1490)	85

Options

Strainer removes contaminants from airline.

Part # W680-765



Oiler assures lubrication of internal components in pneumatic head

Part # W680-770





Internal Pneumatic Vibrators **WPV Series**

Durability... hardened steel components provide maximum operational hours

Powerful... high frequency and high amplitude of vibration

Simplicity... low maintenance bearingless air vibrator

Safety... work without electricity

- Maintenance-free handle with a valve admission system
- Oil reservoir, prepared for several days (fill at least once a week under normal conditions)
- Optimal relationship between frequency and amplitude for the right concrete compaction
- Standard 7' handling hose



WPV System

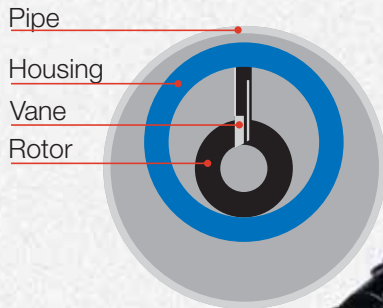

Specifications

MODEL	Diameter inches	Length inches	Weight lbs	Frequency vpm	Air Consumption cfm	Performance yards ³ /h
WPV 25	1	9	5.5	20,000	14	5
WPV 40	1.5	12	10	19,000	18	18
WPV 50	2	12	14	18,000	21	29
WPV 60	2.375	12	15	17,000	26	35
WPV 80	3	13.5	28	15,000	44	50



8635 Washington Ave. • Racine, Wisconsin 53406
 Telephone: (262) 639-6770 or 1-800-233-9926
 Fax: (262) 639-2023 or 1-888-992-6872
 Website: www.wycotool.com
 E-Mail: wycosales@wycotool.com

PRINTED IN USA 7/06
 FORM NO. W-106